



Metalbilt® Aluminium Vision Roller Shutters

Applications

Bar tops, counter tops, shop fronts, pedestrian openings, malls or anywhere that requires a high level of visibility and finish.

Features

- Curtains are constructed from individual extruded aluminium slats incorporating U.V. resistant acrylic panels at 300mm centres providing a rigid attractive rolling closure. Also available as a solid Aluminium Shutter where vision is not required
- Operation by spring balance or motorised
- Fixed or removable mullions options are available
- Slot size 42.5mm x 225mm
- An extensive range of powder coating colours can be offered
- Grilles are custom made to fit the size of opening and structure of building
- Sales Asia Oceania wide
- Branches in Auckland, Wellington and Christchurch

*55 years of manufacturing experience and continuous refinement.
Service and repairs, 24 hours a day, on all makes of commercial doors.*

Metalbilt® Aluminium Vision Roller Shutters – Specifications

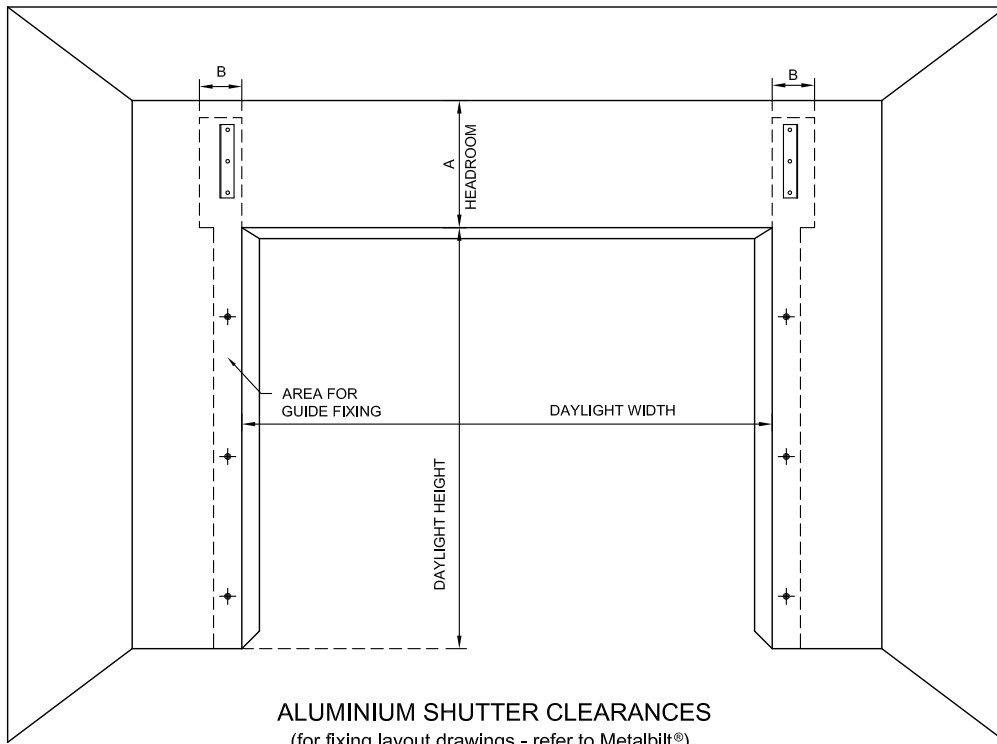

ALUMINIUM SHUTTER CLEARANCES

(for fixing layout drawings - refer to Metalbilt®)

HEIGHT OF OPENING	HEADROOM	SIDEROOM	INSIDE PROJECTION BARREL	INSIDE PROJECTION MOTOR	GUIDE PACKER SIZE
(m)	A	B	C	D	E
0 - 1.25	350	120	300	550	0
1.25 - 2.0	370	120	330	580	0
2.0 - 3.0 *	390	120	360	600	40
3.0 - 4.0	420	120	390	615	50
4.0 - 5.0	450	120	420	630	50

* Maximum Spring Balance Size = 3.0m High x 4.0m Wide
Maximum Motorised Size = 5.0m High x 5.8m Wide

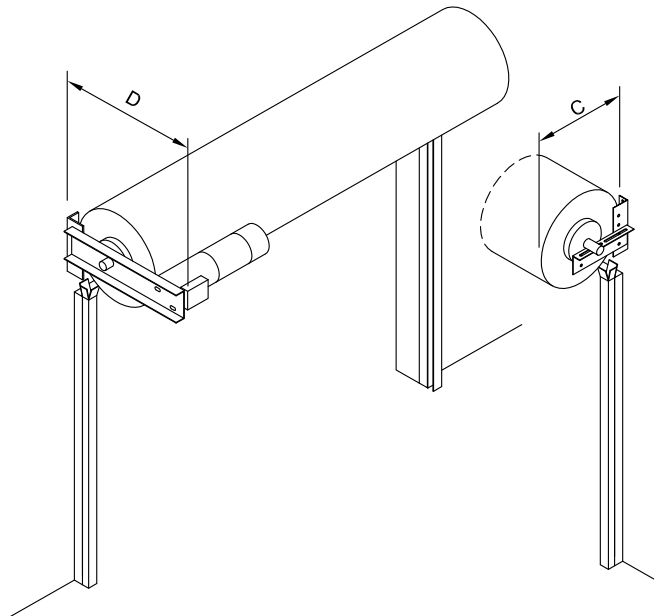

GUIDE DETAILS

Packer by others (to lintel only)

CURTAIN

Assembled from extruded aluminium interlocking sections. Slats may be prepunched for ventilation, or to accept a continuous clear acrylic vision panel. Each alternate slat is fitted with a nylon end lock to control lateral movement. The slats can be replaced individually if damaged.

Fitted to the lower edge of the curtain is an extruded aluminium bottom bar.

GUIDES

Specially extruded aluminium channel 40mm x 30mm. Guides screwed to jambs at max. 600mm centres. Each guide is constructed with a bell mouth to facilitate smooth entry of the curtain.

FINISH

Clear anodised or powder coated.

BARREL

Barrels are fabricated from mild steel tube with a minimum diameter of 165mm and of sufficient wall thickness to ensure that nominal deflection does not exceed safe working conditions. Helically wound counterbalance springs are contained within the barrel.

SECURITY

Flush mounted lock with various keying options.

OPERATION

Spring balanced or motorised. Motorised shutters have single phase motorsets with adjustable limit switches and control pendant. Operating speed is approximately 200mm per second. The motorsets incorporate an automatically engaging handchain for use during power failures. Battery backup systems are available.

Key switches and door controllers to accept signals from a range of activation features are also available. Special motorising options and barrel mounting methods are available on request.

Standard doors meet the 5 year durability requirements of the N.Z.B.C. Details available on request.

We reserve the right to alter specification without notice and without incurring obligation.

Contact details of your nearest Metalbilt® representative:

Auckland
Postal Address
PO Box 71169 Rosebank
Auckland 1348 New Zealand
Street Address
26 Timothy Place Avondale
Auckland 1026 New Zealand
Phone 09 828 1167
Fax 09 828 6358
Email mbilt.auck@metalbilt.co.nz

Christchurch
Postal Address
PO Box 6033 Upper Riccarton
Christchurch 8442 New Zealand
Street Address
25 Baigent Way Middleton
Christchurch 8024 New Zealand
Phone 03 338 2600
Fax 03 338 4386
Email mbilt.chch@metalbilt.co.nz

Wellington
Postal Address
PO Box 38933 Wellington Mail Centre
Lower Hutt 5045 New Zealand
Street Address
33 Marsden Street Melling
Lower Hutt 5010 New Zealand
Phone 04 568 2933
Fax 04 568 7337
Email mbilt.well@metalbilt.co.nz

Metalbilt®
DOORS

NORFOLK
INTEGRATED ENGINEERING

www.metalbilt.co.nz