



12mm Tube Aluminium Rolling Grilles

Applications

Bar tops, counter tops, shop fronts, pedestrian openings, arcades or anywhere that requires a high level of visibility and finish.

Features

- Curtains are constructed from individual 12mm diameter aluminium tubes connected with black nylon links
- Operation by spring balance or motorised
- Fixed or removable mullions options are available
- An extensive range of powder coating colours can be offered
- Grilles are custom made to fit the size of opening and structure of building
- Sales Asia Oceania wide
- Branches in Auckland, Wellington and Christchurch

*55 years of manufacturing experience and continuous refinement.
Service and repairs, 24 hours a day, on all makes of commercial doors.*

12mm Tube Aluminium Rolling Grilles – Specifications

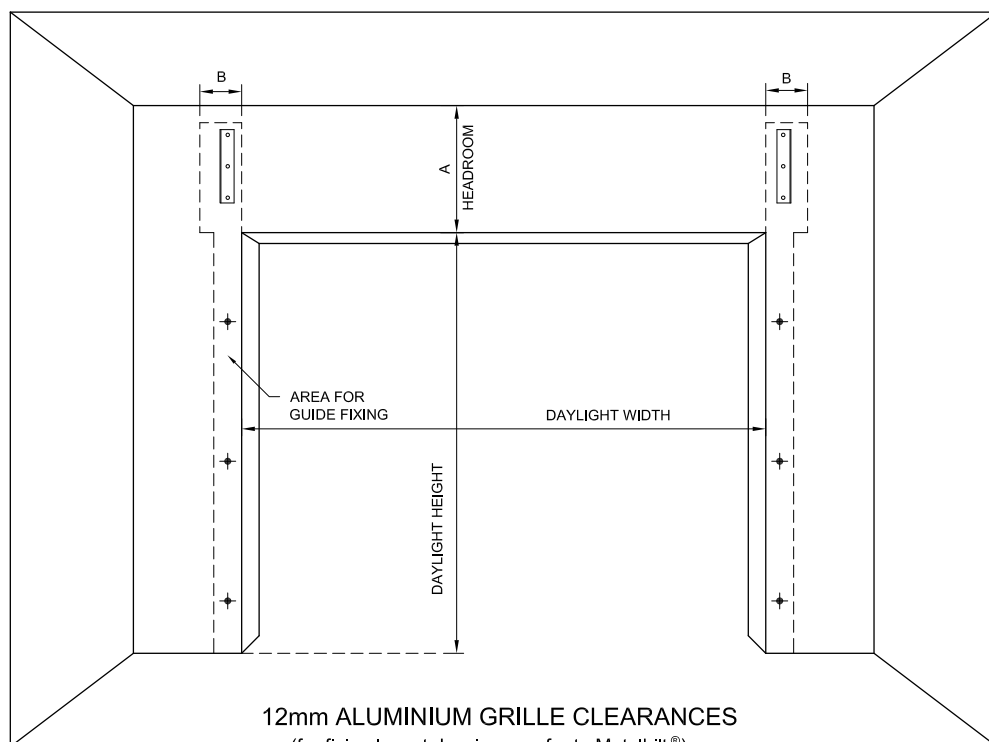

12mm ALUMINIUM GRILLE CLEARANCES
(for fixing layout drawings - refer to Metalbilt®)

| HEIGHT OF OPENING | HEADROOM | SIDEROOM | INSIDE PROJECTION BARREL | INSIDE PROJECTION MOTOR | GUIDE PACKER SIZE |
|-------------------|----------|----------|--------------------------|-------------------------|-------------------|
| (m) | A | B | C | D | E |
| 0 - 1.25 | 380 | 120 | 360 | 550 | 0 |
| 1.25 - 2.0 | 400 | 120 | 390 | 580 | 0 |
| 2.0 - 3.0 | 450 | 120 | 440 | 610 | 40 |
| 3.0 - 4.0 * | 500 | 120 | 475 | 625 | 50 |

* Maximum Manual Size = 3.5m High x 4m Wide
Maximum Motorised Size = 4m High x 5.5m Wide

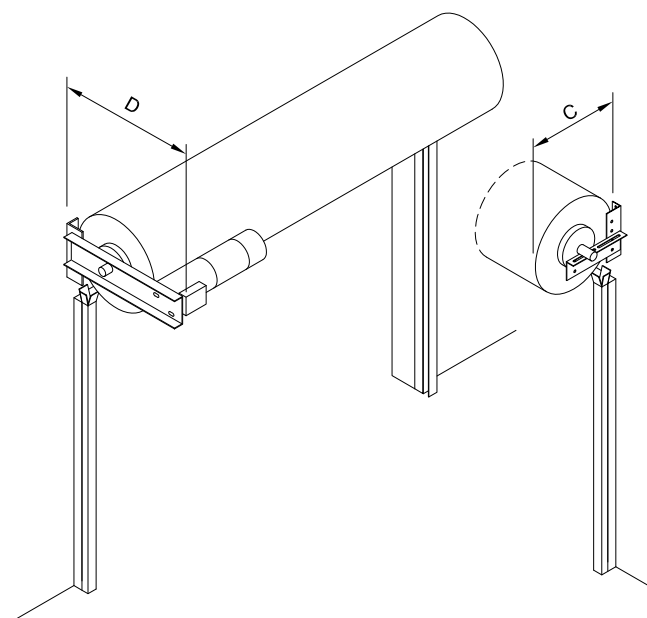

GUIDE DETAILS

Packer by others (to lintel only)

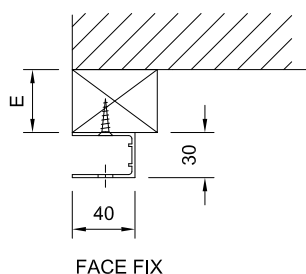

FACE FIX

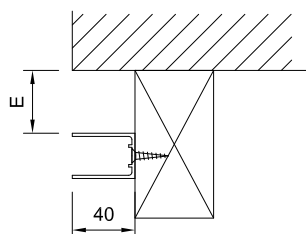

BACK FIX

CURTAIN

Assembled from 12mm aluminium tubes and moulded nylon links into a brick pattern. The tubes and links can be replaced individually if damaged. Fitted to the lower edge of the curtain is an extruded aluminium bottom bar.

GUIDES

Specially extruded aluminium channel 40mm x 30mm. Guides screwed to jambs at max. 600mm centres. Each guide is constructed with a bell mouth to facilitate smooth entry of the curtain.

FINISH

Clear anodised or powder coated.

BARREL

Grille barrels are fabricated from mild steel tube with a minimum diameter of 165mm and of sufficient wall thickness to ensure that nominal deflection does not exceed safe working conditions. Helically wound counterbalance springs are contained within the barrel.

SECURITY

Flush mounted lock with various keying options.

OPERATION

Spring balanced or motorised. Motorised grilles have single phase motorsets with adjustable limit switches and control pendant. Operating speed is approximately 170mm per second. The motorsets incorporate an automatically engaging handchain for use during power failures. Battery backup systems are available.

Key switches and door controllers that accept signals from a range of electronic and electrical equipment are also available. Special motorising options and barrel mounting methods are available on request.

Standard doors meet the 5 year durability requirements of the N.Z.B.C. Details available on request.

We reserve the right to alter specification without notice and without incurring obligation.

Contact details for your nearest Metalbilt® representative:

Auckland
Postal Address
PO Box 71169 Rosebank
Auckland 1348 New Zealand
Street Address
26 Timothy Place Avondale
Auckland 1026 New Zealand
Phone 09 828 1167
Fax 09 828 6358
Email mbilt.auck@metalbilt.co.nz

Christchurch
Postal Address
PO Box 6033 Upper Riccarton
Christchurch 8442 New Zealand
Street Address
25 Baigent Way Middleton
Christchurch 8024 New Zealand
Phone 03 338 2600
Fax 03 338 4386
Email mbilt.chch@metalbilt.co.nz

Wellington
Postal Address
PO Box 38933 Wellington Mail Centre
Lower Hutt 5045 New Zealand
Street Address
33 Marsden Street Melling
Lower Hutt 5010 New Zealand
Phone 04 568 2933
Fax 04 568 7337
Email mbilt.well@metalbilt.co.nz



www.metalbilt.co.nz

NORFOLK
INTEGRATED ENGINEERING